

The Hybrid IW/IED Network-defeat Toolkit - Cultural Immersion & More

Mr. Benjamin Jordan
TRADOC G-2 Intelligence Support Activity
Fort Leavenworth, KS
benjamin.jordan@us.army.mil

Mr. Mel Cape
Booz Allen Hamilton, Inc.
Fort Leavenworth, KS
melvin.cape@us.armu.mil

Mr. Joe Gonzalez
Texas A&M University System
College Station, TX
jgonzalez@tamu.edu

ABSTRACT

A fundamental truth of warfare is its attendant ambiguity. This ambiguity constrains our knowledge and understanding of the attitudes, events, activities, and information exchange mechanisms composing the operational environment (OE). We piece together our understanding as best we can but there are gaps. We aggravate the gaps by tending to focus our metrics on events and activities that are quantifiable. We know these metrics are incomplete but often let them shape our TTP. We also know there are sources of critical information that can help mitigate these gaps and allow a more complete view of the OE. One source most soldiers are ill-equipped to engage is the noncombatant population. A more complete and accurate perception of the battle space through training can only occur if these other information sources are captured in a cost-effective, repeatable, and reasonably accurate irregular warfare (IW) simulation.

The TRADOC G-2 Intelligence Support Activity has embraced this challenge, matched it to OE gaps in models and simulations (M&S), and developed a training federation to provide an immersive prototype trainer for soldiers, leaders, and commanders to conduct intelligence penetration with respect to Improvised Explosive Device (IED) networks. The federation is the **H**ybrid **I**W/**I**ED **N**etwork-defeat **T**oolkit (HI²NT) and will be comprised of six major components: a first person cultural trainer (FPCT), a ground maneuver model (One Semi-Automated Force), a noncombatant effects model (Joint Non-kinetic Effects Model), a massively multiplayer online environment (MMO), an AAR model (Dismounted Infantry Virtual After Action Review System) and a data exchange gateway (the Simulation Object Runtime Database).

HI²NT creates a cohesive virtual and constructive environment wherein soldiers establish rapport, garner trust, derive, and share combat intelligence from the noncombatant population to reduce OE ambiguity and quickly see the results of their efforts. This capability provides a more complete and relevant training experience to soldiers and leaders in their preparation for operational deployment.

ABOUT THE AUTHORS

Benjamin Jordan is Director of the Models and Simulation Directorate and Operational Environment Lab for the U. S. Army's Training & Doctrine Command's Intelligence Support Activity at Fort Leavenworth, Kansas. He is a former U.S. Marine infantryman who served in Southeast Asia (SEA), was later commissioned into the Army and was branched in Military Intelligence, Special Forces, and as a SEA Foreign Area Officer; he holds a MA in SEA Studies from Cornell University; he retired in 1996.

Mel Cape is a consultant with Booz Allen Hamilton and currently serves as Senior Concept Modeler and Knowledge Engineer for the Model and Simulation Directorate and Operational Environment Lab for the U. S. Army's Training & Doctrine Command's G-2 Intelligence Support Activity at Fort Leavenworth, KS. He specializes in conceptual design and methodology development for Army warfighting functions with respect to the operational environment. Mr. Cape, a retired Army Lieutenant Colonel, holds a Masters in Information Technology Management and has served in a variety of model and simulation related positions.

Joe Gonzalez works for the Texas Engineering Experiment Station, Texas A&M University System. He is the System Integrator for the HI²NT Federation and supports the development of COE capabilities for the TRADOC G-2 Intelligence Support Activity. Mr. Gonzalez is a retired Army officer who has held the positions of Associate Professor, Department of Civil and Mechanical Engineering, United States Military Academy, West Point, NY; Deputy Vice-Director, Battle Command Battle Laboratory, Fort Leavenworth, KS; and Deputy Director, Experimental Force (EXFOR) Coordination Cell, Fort Hood, TX. He holds a M.S. in Mechanical Engineering from Kansas State University and a B.S. in General Engineering from the United States Military Academy.

The Hybrid IW/IED Network-defeat Toolkit – Cultural Immersion & More

Mr. Benjamin Jordan
TRADOC G-2 Intelligence Support Activity
Fort Leavenworth, KS
benjamin.jordan@us.army.mil

Mr. Mel Cape
Booz Allen Hamilton, Inc.
Fort Leavenworth, KS
melvin.cape@us.army.mil

Mr. Joe Gonzalez
Texas A&M University
College Station, TX
jgonzalez@tamu.edu

INTRODUCTION

Significant effort has been expended to mitigate the effects of Improvised Explosive Device (IED). Much of the effort has addressed technical solutions to identify, render safe, pre-detonate, or employ “right of the boom” forensic analysis on IED events; that is to neutralize IEDs once found and to discover how they work and the material source after they have been detonated. However, in the last year, considerable effort has also been expended on solutions that preemptively identify and reduce the IED network to disrupt the IED life-cycle (“left of the boom”); that is to eliminate or reduce the number of IEDs manufactured and emplaced. A key part of these efforts, however, have only focused on technical solutions to ascertain critical pieces of the IED life-cycle.

The following questions are central to attacking the network (AtN) and the entire IED lifecycle: who is the supplier, what materials are being supplied, where is manufacturing taking place (and by whom), who is storing, distributing, and emplacing the devices, and how, when, and by whom are they detonated. It is clearly more cost effective, in terms of resources and human casualties, to succeed “left of the boom”. There is one information source, critical to answering these questions, that the vast majority of soldiers are ill equipped to exploit; the noncombatant population. These are the people who live in the battle space and in general act in ways that assure their own survival. As essential parts of the neighborhood they are in general keenly aware of what belongs, what is out of place, and most importantly those people and events that are not part of the essential elements of daily life in their neighborhood. Discovery of this information can be difficult as it is hidden behind the cultural mores, activities (coercive and persuasive), and trepidation experienced by the civilian population.

We must take advantage and leverage this key source of information by developing tools that can be used to train soldiers and leaders to understand how this information can potentially be harvested through thoughtful cultivation of cultural understanding and negotiation. Effective cultural trainers could be the catalyst for this process by enabling soldier’s to make contact and discover opportunities in a comprehensive and culturally accurate simulated training environment to gain the requisite knowledge and experience prior to operational deployment.

DEVELOPING A SOLUTION

TRISA Effort

The TRADOC G-2 Intelligence Support Activity (TRISA), Operational Environment (OE) laboratory is developing the Hybrid Irregular Warfare (IW)/IED Network-defeat Toolkit (HI²NT) prototype to provide such a tool that will enable a combat training center (CTC)-like training platform for current and future force officer and non-commissioned officer (NCO) leadership, and soldiers to plan for the use of Counter-IED (C-IED) technologies, interact in diverse cultural settings, understand the consequences of various force activities in these settings, and hone negotiating skills required to derive critical combat IED network intelligence from the local population.

The HI²NT is designed to be a live, virtual, and constructive (LVC) multi-echelon training simulation. It addresses specific C-IED tactics, techniques, and procedures (TTP), and methods to AtN at the tactical level, while preparing soldiers and leaders to successfully interact in foreign cultures to obtain actionable intelligence to assist in these activities.

HI²NT is being developed in four one-year spirals to achieve a cultural training federation developed by modifying and integrating simulations under

development and on hand at the OE Lab, Fort Leavenworth, KS (See Figure 1). The realized HI²NT federation will be composed of six major components; the First Person Cultural Trainer (FPCT) a virtual “first person” cultural driver; the One Semi-Automated Force (OneSAF) simulation, the ground maneuver (force-on-force) model; the Joint Non-kinetic Effects Model (JNEM), a noncombatant effects (relationship) model; a massively multiplayer online (MMO) environment as a virtual in-world model to be determined; the Dismounted Infantry Virtual After Action Review System (DIVAARS) for after action review (AAR); and finally the Simulation Object Runtime Database (SORD) Gateway and ProtoCore API for data connectivity.

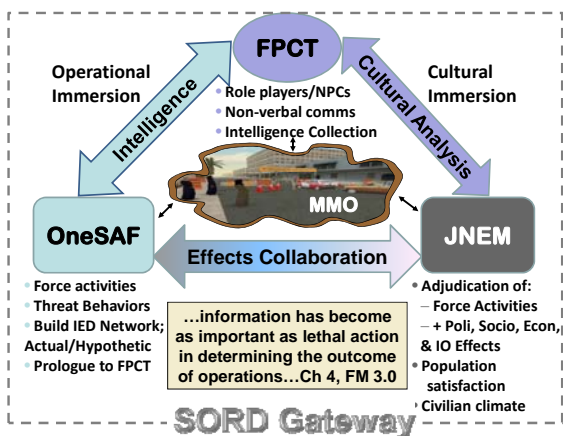

Figure 1. HI²NT Conceptual Architecture

With exception of DIVAARS, all federates are mature models requiring only integration work to enter the HI²NT federation. The HI²NT prototype effort has completed Spiral 1 and is currently in Spiral 2. Each development spiral will produce an accumulating set of capabilities useful to the force with the final prototype being hosted via a MMO environment. This will provide the training audience with both sufficient risk (the inability or constrained ability to attack the network with related consequences) and opportunity (the proper use of force activities in combination with cultural bona fides leading to actionable combat intelligence) that over time enables effective mitigation or defeat of the IED network.

This LVC federation will provide a multi-player, multi-echelon, and multi-unit capability that exercises leaders and their staffs in training to preempt and defeat IED use against coalition and non-combatants via AtN TTP specifically enabled by the use of cultural interaction and negotiation with the noncombatant population to develop IED network intelligence.

Operational Perspective

In the current operational environment tactical leaders daily face interacting in cultures that may be unfamiliar to them, and are composed of varying traditions, norms, and taboos. In order to effectively gather intelligence in this, usually asymmetric, battle space leaders must interact with their target culture as seamlessly as possible, and at a minimum without offense. Upon successful local interaction and acceptance, the tactical leader may gain, through thoughtful negotiation insights to IED network activities, membership, and TTP.

The HI²NT federation will enable brigade and below tactical leaders to not only plan for the use of current “left of the boom” technologies to mitigate IED emplacement, but to interact with indigenous leaders and determine, over time, the composition and disposition of IED networks and supporting mechanisms. From an operational perspective, this means tactical leaders, fire team through brigade, can exercise their knowledge of existing C-IED technologies as well as cultural communication and intelligence gathering skills with indigenous leaders and other noncombatants and have the results of that interaction; whether positive or negative, impact their planning and operations in their battle space.

This cause and effect methodology provided in a synthetic battle space where a leader’s decisions to begin, suspend, or change force activities, coupled with personal interaction with noncombatant leaders can cause outcomes (direct and indirect) within the noncombatant population that enable or constrain the leader’s ability to gain knowledge, identify, and mitigate or defeat the IED network.

Cultural Immersion

The HI²NT federation will immerse tactical leaders in a culturally accurate operational environment representative of the battle space they will operate in. As such, the tactical leader will, commensurate to their mission, plan for the use of C-IED technologies, communicate with local leaders and noncombatants in an effort to establish rapport to achieve increasing cooperation levels, ultimately leading to collaboration with indigenous people to identify the IED network components.

Personal interaction with local leaders in combination with ground maneuver activities (e.g., patrolling, cordon and search, check points, combat operations, civil-military operations, humanitarian relief operations, etc.) will improve or undermine the relationship

between US/Coalition forces and indigenous people groups based how these two factors are integrated in practice. These dynamics shape conditions on the ground and will improve force effectiveness if properly synchronized.

Opportunities for the Military Leader

Through this federation tactical leader's can:

- Learn and apply appropriate, cultural bona fides (including body language), respect traditions, and avoid taboos that should enhance cooperation and build rapport with the local population.
- Demonstrate knowledge and planning skills requisite to the employment of C-IED technologies within the battle space.
- Conduct tactical C-IED and IED Defeat (IED-D) operations and planning while considering cultural implications and consequences and learn how to most effectively manage their use of the set of kinetic activities, non-kinetic activities, and personal diplomacy available to them.
- Obtain local intelligence on IED networks and supporting mechanisms and discover local adversary IED network TTP.
- Impact the operational environment;
 - Positively through IED discoveries “left of the boom”, appropriate cultural interaction, and properly applied non-kinetic battle space activities (e.g. CMO).
 - Negatively through poor communication skills (e.g., inappropriate body language) and kinetic battle space activities (e.g., noncombatant casualties through indirect fire).

FEDERATE DESCRIPTIONS

The HI²NT federates will work together to provide robust representation of kinetic and non-kinetic force activity impacts upon attitudes and cooperation levels between forces and noncombatant groups, as well as the employment of C-IED systems and other technological capabilities as they are fielded to units. The following federate descriptions and related federation functionality will be realized over the four year spiral development effort:

- FPCT: The avatar-based cultural driver provides the tactical leader a first-person interactive interface to indigenous community leaders and members within varied cultural contexts and conditions. FPCT effectively enables multiple individuals to role play as brigade and below tactical leaders or intelligence staff via avatars and interact with Non-Player Characters (NPC) representing selected indigenous community leaders and members with an endstate capability world-wide via Army Knowledge Online (AKO). In future spirals other role players (e.g., subject matter experts [SME]) will be able to represent international organizations, transnational corporations, and non-governmental organizations. Discoverable IED network details (“nuggets”) within the cultural trainer are available and may be successfully learned via negotiation. However, a cultural gaffe on the part of the player will hinder or potentially end information exchange. Culturally appropriate and amenable actions, on the other hand, will lead to the collection of IED intelligence. IED Network details are currently incorporated in the FPCT via prologues developed from OneSAF scenarios. Thus IED networks in the FPCT mirror those in OneSAF. In succeeding spirals, IED network details as well as FPCT based intelligence nuggets will be distributed via the federation data backbone and interactive and dynamic collaboration of OneSAF and FPCT will increase.
- JNEM: The noncombatant effects model monitors, measures, and maintains noncombatant group attitudes, demeanors, cooperation levels, and relationships affecting information exchange between force leaders and community leaders. JNEM will cooperatively exchange with FPCT the attitude and cooperativeness of the represented neighborhood before and after negotiations to account for external force activities and situations as well as the effects of FPCT negotiations on attitude and cooperation. The interaction of tactical leaders in the first person cultural trainer and the force activities performed by force leaders in the ground maneuver model will cause second and third order effects within noncombatant demeanors and attitudes in JNEM. These effects are changes in attitude, reactive events, and changes in cooperation based on interaction with the local population. JNEM will also calculate the effects of related, but non-FPCT, activities (i.e., those activities necessary to discover IED network information) upon the mood of the noncombatant groups thereby influencing their willingness to cooperate. These levels will automatically set

conditions for information sharing in the FCPT, impacting the leader's ability to solicit IED network intelligence. During subsequent development spirals JNEM will be enhanced with additional PMESII (Political, Military, Economic, Social, Infrastructure, and Information systems) based functionality currently being developed for the socio-cultural model prototype, Athena, being developed by the NASA Jet Propulsion Laboratory (JPL).

- **OneSAF:** The ground maneuver model provides kinetic and non-kinetic force activities that can impact noncombatant group attitudes and cooperation levels monitored in JNEM thereby enhancing or constraining interaction between the force leaders and indigenous leaders in FPCT. Force activities will occur in predetermined vignettes within OneSAF to provide threads of information concerning IED networks (components, storage, distribution, manufacture, emplacement methods, targets, etc.). This information is provided to force leaders in FPCT interacting with community leaders and members as the vignette unfolds. During subsequent development spirals OneSAF will initialize the federation with the scenario and IED network information and allow reaction and response to FPCT discovered nuggets as part of the C-IED training objective.
- **MMO Environment:** The specific virtual in-world model system to be used is to be determined and currently in the selection process by U. S. Army's Research, Development and Engineering Command (RDECOM), Simulation & Training Technology Center (STTC). The MMO environment will provide a virtual CTC-like environment to the HI²NT federation and provide first person avatar-based interaction within a force-on-force context and will link directly to OneSAF to provide visualization of the maneuver space and the force activities therein. This capability will be developed in subsequent spirals and is key to the HI²NT prototype end-state capabilities.
- **DIVAARS:** The AAR model provides a replay, post-event mentoring capability to the federation by visualization of the battle space with respect to relationships and cooperation levels among non-combatants, visually reflecting the changing moods, demeanors, and attitudes based on feeds from the FPCT and the JNEM models during and after training.

- **SORD/ProtoCore:** The data SORD gateway model developed by RDECOM-STTC provides an efficient conduit through which data can be passed as a function of federate subscriptions. This mitigates, but does not eliminate the need for a HI²NT federation object model (FOM). ProtoCore, also developed by RDECOM-STTC, serves as a multi-function API, and in conjunction with SORD, to provide HLA connectivity among the HI²NT federates for data that must be distributed via a FOM. The FOM for Spiral 2 is the Joint Land Component Constructive Training Capability (JLCCTC) Entity Resolution Federation (ERF). The HI²NT federation will migrate to the Modeling Architecture for Technology, Research, and Experimentation (MATREX) FOM by the end of Spiral 3.

Other organizations and initiatives that will play a potential part in the overall development of the HI²NT federation in Spiral 3 and 4 include:

- **Joint Forces Command's (JFCOMs) efforts** with the Virtual Cultural Awareness Trainer (VCAT). VCAT is an immersive cultural training environment providing cultural reference and regional information as a front-end to the FPCT. It is not a free-play or scenario driven trainer but allows for cultural familiarization via a virtual world interface.
- **TRADOC Culture Center products** derived from their research into specific cultures world-wide provide the FPCT training audience exposure to their target culture for familiarization prior to FPCT game play.

SPIRAL DEVELOPMENT

As previously mentioned, the federation development will consist of four spirals conducted over a four year period, each building on the success of the previous spiral; beginning with a decision tree based model using canned scenarios and one-on-one role play, and progressing to a final spiral of free play scenarios involving many-to-many role players via an MMO. The spiral development cycles are:

Spiral 1

Spiral 1 is complete. Its focus was the development of the core capabilities of the FPCT and the testing of the SORD/ProtoCore connectivity with federate surrogates. As the cultural training model for brigade and below tactical leaders it allows individual role player interaction (one-to-one, avatar-based) with individual,

indigenous leaders/members within a local population where the attitudes, feelings, and relationship of those indigenous leaders/members can change as a result of that interaction. For example, changes in indigenous leaders can occur as a result of proper or improper local etiquette (e.g., use of body language or communication taboos). This results in a trainer that can be used to interact with a culture to learn the cultural mores/values as well as develop and improve interview techniques for useful information exchange with leaders. Successful negotiation during this one-on-one interaction can result in the discovery of intelligence, e.g., basic IED network information. The focus on intelligence gathering progresses through four levels. Level 1, identification of and introductions to cultural leaders; Level 2, proper conduct at various meetings or social interactions/functions; Level 3, determining key religious, political, and economic actors/leaders/players; Level 4, discerning the key actors attitudes toward US/Coalition forces and various force activities, and derivation of IED related combat intelligence. HI²NT/FPCT Spiral 1 was delivered in October 2009.

During Spiral 1 limited user testing and controlled laboratory evaluation was conducted of the FPCT prototype utilizing both Iraq and Afghanistan cultural data. Useful feedback concerning NPC interview techniques, player user interface, cultural discriminators, and after action review during play and post play review capabilities (called a scorecard in the Spiral 1 version of the FPCT) was received and integrated.

Spiral 2

Spiral 2 combines the FPCT, JNEM, and the OneSAF federates to provide federation level attitude and cooperation management and high fidelity ground maneuver capabilities. Exploiting the success of Spiral 1, interaction now evolves to many-to-many role playing where multiple soldiers/leaders can now affect multiple relationships and effect information flow within the battle space. With the addition of OneSAF, assorted force activities (e.g., direct and indirect fire, maneuver, and establish checkpoint) will further influence the player's ability to gather IED network intelligence. Data exchange via these federates will be accomplished via a combination of the SORD Gateway and ProtoCore API (See Figure 2). Spiral 2 will demonstrate the federation's initial ability to synchronize, exchange, and leverage each federate's capability in a collective sense.

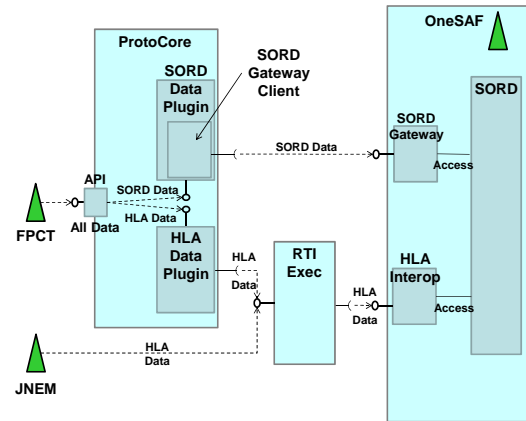

Figure 2. HI²NT Spiral 2 Data Architecture

Spiral 3

Spiral 3 will bridge the gap between limited connectivity and full federation synchronization. During Spiral 3 the MMO environment will be selected and its initial integration with the HI²NT federation will start. Also the AAR capability and C-IED planning functionality for the training community will be integrated. In this spiral, real players (SME, Controllers) will have the ability to be used in lieu of computer controlled non-player characters (NPC). This will enable more in depth and fluid interviews, to accomplish specific training objectives, and will assist in conducting AARs. This interactive training capability will be enhanced as cultural SMEs can bring more complete cultural behavior sets and more involved exchanges and negotiations to HI²NT. Results of these interactions will be passed back to the ground maneuver model via live staff action to better facilitate the tactical leader's military decision making process concerning what activities (CMO, stability operations, HRO, etc) are most appropriate in accomplishing the mission. Instead of effects being applied uniformly across the battle space, rates of information exchange may differ in different neighborhoods or local areas driving and reacting to local kinetic and non-kinetic activities; achieving greater OE fidelity.

Spiral 4

The federation integration and capability development of the HI²NT prototype culminates in Spiral 4. It will provide free play scenarios involving many-to-many role players in a 3-D virtual environment fed by a ground maneuver model where force effects are adjudicated and applied to relationships between combatants and noncombatants.

By the end of spiral 4, OneSAF “free play” will drive unique interaction between role players within the first person virtual cultural trainer (FPCT) and the MMO virtual in-world with JNEM acting as the cultural driver. As depicted in Figure 3, the objective HI²NT federation will feature a robust framework creating a virtual environment suitable to training for IED AtN.

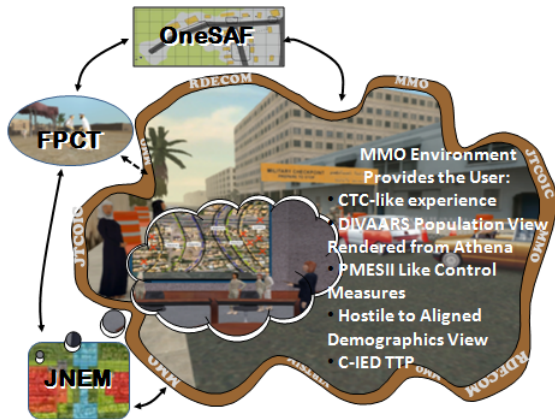

Figure 3: Objective HI²NT Federation.

There have, and will be, successes in the field with respect to IED and IED network discoveries. During the HI²NT development process those successes will be captured and integrated to deliver a training federation that is useful, up to date, robust, flexible, and representative of real-world successes and experiences.

CAPABILITY FOCUS

The TRISA OE Lab will ensure development of HI²NT in a timely and efficient manner by providing tactically sufficient and culturally appropriate tools to the field throughout the build period. This will also allow user feedback thought the spirals, improving the utility of the product. The federation provides:

- First person interaction and training within cultural norms (based on location, time and situation) in a MMO environment context.
- Multiplayer role play by tactical leaders, staffs and SMEs as force leaders, NGOs, and community leaders.
- Four levels of intelligence gathering functionality leading to the discovery of IED Networks and their support mechanisms.
- Link to a noncombatant effects driver that measures dynamic civilian attitudes, relationships and cooperation levels impacted by cultural interaction and force activities.

- Link to a force-on-force model, OneSAF, to determine the results of force activities (both kinetic and non-kinetic) from cultural interactions and negotiations and apply those results to OneSAF behaviors.
- Common scenario use, common role play, and multi-player dynamic interaction, as well as the ability to inject activities and events in support of specific training objectives.
- Rehearsal functionality encompassing expected events and the capability for unexpected encounters.
- An AAR tool that can demonstrate causality for IED-D and AtN events, information, and other combat intelligence.
- An IED-D training tool that incorporates all M&S domains; live, virtual and constructive.

CONCLUSION

The HI²NT Spiral 1 was completed and met the threshold requirements to move to Spiral 2. We are currently in Spiral 2 and technical integration to date has been successful.

In its endstate the HI²NT federation will be uniquely suited for cost effective and effective training in Counter-IED and IED-Defeat operations, IED Network Attack operations, and IED recognition integrated with cultural interactions that can serve as a force multiplier. It will incorporate a more complete representation of the OE and include the capability to incorporate those additional aspects in the planning and execution of military operations. It is being developed in spirals that are designed for continual user feedback to be incorporated into the final prototype product.

ACKNOWLEDGEMENTS

The authors would like to recognize the following for their contribution to the HI²NT federation development and feedback in the preparation of this technical paper:

- Dr. Thomas Linehan and Dr. Marjorie Zielke (FPCT Federate), the Institute for Interactive Arts and Engineering (IIAE) at the University of Texas at Dallas (UTD).
- Mr. Julio de la Cruz (SORD Gateway and DIVAARS Federate), U.S. Army Research,

Development, and Engineering Command (RDECOM), Simulation & Training Technology Center (STTC).

- Dr. Dave Nash (OneSAF Federate), PM OneSAF-Orlando IDE.
- Mr. Joe Provenzano (JNEM/Athena Federate), NASA Jet Propulsion Laboratory.

In addition, we'd like to give a word of appreciation to our comrades-in-arms from the U.S. Marine Corps for their input, feedback on federates, and sage advice: LtCol William Yates, PM Training Systems; Dr. Michael Woodman, TECOM, MAGTF TSD; Gary Purdy-CAOCL; and Mr. Austin Bryant, MCTOG.

REFERENCES

TRADOC Intelligence Support Activity (2010). *HF²NT Concept paper*. 26 May 2010.

TRADOC Intelligence Support Activity (2010). *HF²NT Concept brief*. 26 May 2010.

TRADOC Intelligence Support Activity (2010). *HF²NT Requirements Document*. 26 May 2010.

TRADOC Culture Center (2003). *Tactical Questioning: Soldier's Handbook*. November 2003.

US Marine Corps (2009). *Cultural T&R Manual, NAVMC3500.65*. 8 April 2009.

JIEDDO (2009). *JIEDDO/DIA Weapons Technical Intelligence (WTI) Handbook V3*. 5 March 2009.

FM 7.0 "Train the Force" 22 October 2002.