

Distributed Synchronized Playback Protocol and Implementation

Terry McDermott, Lacey Ashkar
Cobham Analytic Solutions
Orlando, FL
Terry.McDermott@cobham.com
Lacey.Ashkar@cobham.com

Ty Knight,
Northrop Grumman Corp.
Orlando, FL
Ty.Knight@ngc.com

Randy Pitz
The Boeing Company
St. Louis, MO
Randy.Pitz@boeing.com

ABSTRACT

Critique and review are critical to the training process. When the training audience is scattered geographically, as happens with distributed simulation based training, new challenges are faced to provide commonly expected review tools. One important feature of military simulation-based training is the ability to play back the action from a just completed training event to support review and evaluation. Playback capability is common in virtual simulator facilities, but presents new challenges in a distributed training environment. Retransmitting recorded data to all sites from a recording site is subject to several criticisms: cost of bandwidth; special configuration of the playback site, potential security issues; and problems maintaining privacy of "local" data. Voice coordinated playback across sites suffers from distractions due to human error and communication problems often resulting in reduced synchronization and wasted time. To overcome all these drawbacks, the Combat Air Force Distributed Mission Operations (CAF DMO) program is pursuing a solution to distributed playback based on the Distributed Debrief Control Protocol (DDCP) recently offered to the simulation community by The Boeing Company. This open protocol is designed to enable the synchronous playback of data recorded in a simulation based event while not requiring recorded data to be retransmitted. CAF DMO is standardizing on the application of the DDCP protocol, tailored toward ensuring interoperability of control programs and playback device programs developed by different vendors. Software conforming to the tailored protocol has been developed and demonstrated that allows centralized, remote control over devices playing back video, simulation data and other information in any combination. This paper summarizes the CAF DMO decision to use DDCP and the tailoring done to achieve standardization.

ABOUT THE AUTHORS

Terry McDermott is a Systems Engineer with Cobham Analytic Solutions. He has been spent over 25 years in modeling, design and development of distributed systems, including systems for ground air defense, geographic information, weather information, and modeling and simulation. He has been supporting standardization efforts for the Combat Air Force Distributed Mission Operations since that program was initiated. Other technical interests include image processing, geo-referenced data information systems, software and systems engineering. He holds an MA and PhD in mathematics from the University of Southern California.

Lacey Ashkar is a Systems Engineer with Cobham Analytic Solutions supporting testing and standards development for real-time distributed simulation infrastructure. She earned her B.S. in Computer Engineering from the University of Florida and her M.S. in Management Science and Engineering from Stanford University.

Ty Knight is a Software Engineer at Northrop Grumman Information Systems and works primarily supporting the CAF DMO Operations and Integration team. Prior to joining Northrop Grumman 4 years ago, Mr. Knight spent 16 years in the telecommunications field working with communication protocols such as MGCP, h.248, and SIP. Mr. Knight holds a bachelor's degree in Computer Science from the University of Central Florida.

Randy Pitz has been involved in distributed simulation system development for 12 years. He currently holds the title of Chief Architect for the Instructor Systems and Tools group within Boeing Training Systems and Services. He recently led the Distributed Debrief Control Protocol Study Group within SISO and has been involved in debrief systems and technology for many years. He has worked on many other projects involving simulation networking technology and instructor operator stations for various training system programs. Mr. Pitz holds a Master's Degree in Computer Science from Washington University and a Bachelor's Degree from Michigan Technological University.

Distributed Synchronized Playback Protocol and Implementation

Terry McDermott, Lacey Ashkar
Cobham Analytic Solutions
Orlando, FL
terry.mcdermott@cobham.com
lacey.ashkar@cobham.com

Ty Knight,
Northrop Grumman Corp.
Orlando, FL
ty.knight@ngc.com

Randy Pitz
The Boeing Company
St. Louis, MO
Randy.pitz@boeing.com

MOTIVATION AND BACKGROUND

Critique and review are recognized as critical to the training process. When the training audience is scattered geographically, as happens with distributed simulation-based training, new challenges are faced to provide commonly expected review tools. One important feature of military simulation-based training is the ability to play back the action from a just-completed training event to support after action evaluation. This capability is common in virtual simulator facilities, but presents new challenges in a distributed training environment.

The obvious approach for distributed playback is to retransmit recorded data to all sites from a single recording site. This approach is often feasible, but it is also subject to several potential drawbacks: cost and availability of bandwidth for re-broadcast; special configuration of the record/playback site; and potential security issues or problems maintaining privacy of "local" data. An alternative playback approach is to use voice coordination to synchronize playback across sites, e.g., "three, two, one, play." This approach suffers from the need for human intervention at every site to maintain synchronization through phases of playback (pause, resume, go back, restart, etc.). Human error is inevitable, and confusion can result in undesirable distractions and loss of synchronization.

The Combat Air Force Distributed Mission Operations (CAF DMO) program is developing the CAF DMO Network (DMON) to provide routine, distributed, inter-team training for CAF platforms. The DMON hosts simulator platforms and sites that are independently designed and developed by a variety of contractors. Today, there are over 30 Mission Training Centers (MTCs) and other training sites on the DMON, including sites in CONUS, Europe, and Japan. More are being added on an ongoing basis.

For CAF DMO, all of the problematic issues mentioned in the last paragraph apply to the possibility of providing exercise playback by re-broadcast or voice-based synchronization. To maximize benefit to

the warfighter, there is also a desire to synchronously play back data that are never shared across the DMON and, therefore, can only be recorded locally where it is produced (e.g., instruments, switch states and workstation displays). This last need simply cannot be met by the retransmission approach and complicates attempts at voice-based synchronization.

DISTRIBUTED DEBRIEF AND SYNCHRONIZED PLAYBACK FOR CAF DMO

In the 2002 time frame, the CAF DMO Operations and Integration (O&I) contractor, Northrop Grumman, performed a requirements evaluation to determine the functions needed to meet user expectations for briefing and debriefing. One of the findings was the need to play back recorded data during debrief, including simulation logs, audio, and video. The issues surrounding playback of non-shared, locally recorded data, data security, and network resources for playback were scrutinized. This determination led to a preliminary conclusion that the capability to centrally control playback of locally recorded data without data retransmission had the strongest potential. Survey and analysis concluded that no then-current brief/debrief solution would meet all the CAF DMO requirements for distributed playback and particularly for centralized control without retransmission.

A prototype experiment was undertaken which showed that a "distributed synchronized playback" solution was feasible. Several years then elapsed while the CAF DMO standards and implementation effort remained focused on integration of platforms on the DMON. During that time, the Boeing Company concluded independently to pursue synchronized distributed playback, which led them to develop the Distributed Debrief Control Protocol (DDCP) protocol. When CAF DMO revisited the Distributed Debrief issue in the 2006-2007 time frame, evaluation of the DDCP protocol, as well as a second requirements and market analysis, resulted in the decision to move ahead with a DDCP-based solution.

Making the Distributed Playback Solution Choice

In 2007, the O&I Contractor was asked by Air Combat Command (ACC) to review and assess various proposed solutions for mission playback and to recommend the one that would best suit the needs of the CAF DMO community. A questionnaire was distributed by the O&I to potential sources of synchronized distributed playback solutions requesting information on what support each source's system could provide for CAF DMO debrief requirements, including distributed synchronized playback.

After reviewing initial questionnaire responses, the O&I Contractor contacted each source of candidate solutions for additional information and sent a representative to attend demonstrations, wherever possible. Proposed solutions were in various stages of realization, ranging from operational systems with plans for needed additional development, to a DDCP prototype implementation, to single source, commercial solutions.

The O&I Contractor further refined the requirements with ACC, prioritizing and weighting them for a more detailed analysis of the candidates that best fit the original requirements list. Based on these weights, a weighted score was calculated for each candidate system. The highest priority categories were

- Playback Functions (DVD-like controls, support for voice communications, master/slave control)
- Display Functions (Zooming, perspective views, 2D or 3D de-cluttered big-picture view)
- Life Cycle Attributes (Cost, maintainability, availability, reliability, training)

A sensitivity analysis performed on the requirement weights showed that further refinement of the weights would not significantly affect the weighted ranking of the scores, so the requirements were not refined further. The DDCP solution had the top weighted score. Solutions from SAIC and Visitech were slightly lower.

The DDCP and SAIC BDS solutions each met the fundamental technical requirements for synchronized mission replay on the DMON. One important difference between these alternatives was that the DDCP approach left the possibility open for CAF DMO platform contractors to determine their recording, playback, and presentation needs without being constrained to a common system and vendor. The O&I recommendation was to carefully consider the cost, schedule, and standards impact for the SAIC

BDS and DDCP solutions to decide between those two approaches. Based on those factors, ACC decided to pursue the DDCP solution for CAF DMO.

DDCP APPLIED TO CAF DMO

DDCP Background and Rationale

The DDCP specification defines a set of messages and rules for exchanging them. These form the basis for a controlling software program located at one site, which in CAF DMO is generically called the Master Control program, to exercise control over the playback functions of playback devices located both locally and also at remote sites. The Master Control interfaces to a playback device by way of a software component referred to in CAF DMO as a DDCP Device program, which is located at the device's site. Under this control, devices synchronously play back locally recorded data locally, eliminating the need to rebroadcast recorded data across the inter-site network. Only control commands and status cross the WAN.

As detailed below, Boeing made the DDCP specification available to the simulation community as a step toward developing an open industry standard for remote, synchronous control of playback. The prospect of such a standard fit well with the CAF DMO approach of interoperability through standardization. With the decision to pursue a DDCP-based solution to its playback requirements, CAF DMO undertook development of a tailored version of DDCP with the objective of ensuring interoperability among Master Control programs and DDCP Device programs developed by different vendors. This goal supports the autonomy of its contractors to develop/acquire their own solutions. The tailoring, led by the CAF DMO O&I contractor, has been accomplished by standardizing on certain architectural and operational assumptions along with specific choices for options left open within the protocol specification. The standardization strategy is to narrow implementation choices to those that can be made without resulting in a loss of interoperability. The standardization makes relatively few assumptions about the details of system hardware and functionality and none about the type of recorded data or how they are presented during playback.

DDCP addresses many of the challenges of large scale distributed playback while remaining structurally straightforward. It requires and relies on time synchronization of recording and playback systems to ensure synchronization of data playback. It provides means for issuing commands uniformly across all

involved sites. It limits use of bandwidth by eliminating the transfer of recorded data for event replay, and by passing only control messages such as play, pause, fast-scan, and seek commands. It facilitates preservation of security and privacy policies by enabling synchronization of private data playback during debrief. It supports implementation over any network transmission layer.

By only specifying the means by which control is established and maintained, DDCP leaves flexibility for the details of individual playback and information presentation to the design of the systems incorporating the protocol. In this way, warfighters can keep the benefit of data and presentation solutions tailored to their unique needs. A complete discussion of the DDCP protocol benefits, design, and implementation has previously been published (Pitz, Armstrong, 2007).

Playback Control Architecture for CAF DMO

DDCP messages, or packets, consist of a protocol message header and body. The header contains fields allowing addressing, time stamping, versioning, an indication of purpose, and size/count information to aid in decoding message body content. The message body contains one or more of the DDCP defined “records.” There are twenty-two defined records. Many of these come in pairs representing a command and its required or optional response.

One group of DDCP records is designed to allow devices to discover each other, take on the role of master or controlled device, and join or depart the playback activity. A second group allows a limited sharing of device capabilities, playback data information, and commanding to access specific playback data. A third group of records supports actual commanding for such functions as start, stop, synchronize, speed control, and so on. Finally, records are provided for error reporting and limited support for data management. Besides playback, DDCP also provides basic support for controlling recording, but this capability has not been used for CAF DMO.

DDCP messages are passed between two software elements, one playing the role of master controller, the other that of a controlled device. As mentioned earlier, in CAF DMO, these programs are called the Master Control program and DDCP Device programs. The DDCP protocol does not make assumptions about how many Master Controls and DDCP Devices exist in an application, nor about what DDCP Devices may be controlled by a particular Master Control, nor about where these reside on a network. Also, there is no explicit requirement as to how the DDCP Device

software is related to the one or more physical playback devices it might directly control. On the one hand, this generality is powerful, allowing applicability to variety of potential situations. On the other hand, that generality presents a major risk to interoperability if the software elements are independently developed. To limit this risk, CAF DMO settled on a relatively simple architecture to achieve an initial capability without undue complexity.

The CAF DMO tailoring adopts a single application architecture with three implementation options. The architecture and options are illustrated in Figure 1.

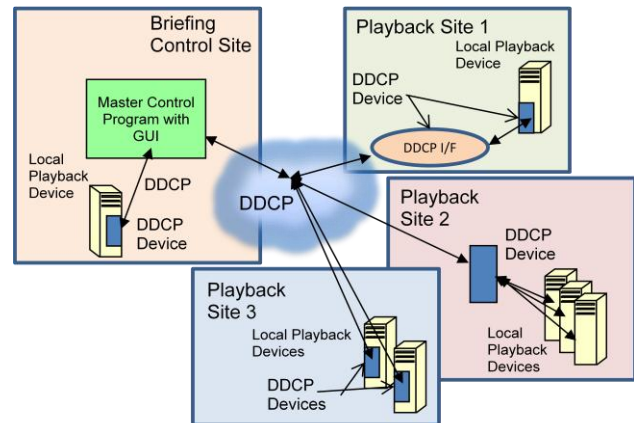

Figure 1. Basic CAF DMO DDCP Architecture

First, there is a single Master Control. Tailoring requirements provide for specific Master Control and DDCP Device actions to prevent multiple Master Control programs from persisting in case operational error starts more than one. The Master Control listens for DDCP Devices and invites them to join the playback as they are detected. Devices always accept the invitation. Site 1 in Figure 1 illustrates the option that a DDCP Device is split into two components. The oval element shown in Site 1 manages the DDCP interface to the Master Control and presents a well-defined software interface to the playback system-specific DDCP Device component of the playback system shown in blue. This option allows a Master Control and the DDCP portion of DDCP Device program to be implemented largely independent of the specifics of a particular playback system, thereby offering potential software development efficiencies. The Site 2 illustration in Figure 1 shows another possibility: that a single DDCP Device actually controls multiple playback systems. The third option illustrated in Site 3 is simply the integration of the entire DDCP Device component into the playback system.

Separation of Function between Master and Device

In general, every effort was made in tailoring to keep the Master Control truly in control of the DDCP Devices. Devices broadcast notification of their presence on the network, but take no actions until requested by the Master Control to join the playback. They tell the Master Control enough that it can tell DDCP Device which of their available data sets to load for playback. A DDCP Device performs a Cue, Start, Pause, Resume, or Stop playback only on command. One of the few actions a DDCP Device is required to take on its own is to smooth over any gaps it may have in a recording while playing is ongoing.

There may typically be many playback devices, and the Master Control attempts to keep them all in the same playback state. If even one encounters a delay, this may have the effect of introducing overall time delays between a Master Control operator input and system response. Provision is made within DDCP, and used in CAF DMO, to make adjustments to bring playback that gets out of synchronization back into synchronization. This allows some latitude to tolerate a level of non-simultaneous responses to commands by DDCP Devices.

Inevitably one or more Devices may encounter errors in trying to respond to a command. Error situations sometime will arise that are too difficult to automatically resolve. When this happens, the tailoring document specifies reliance on operator intervention and sometimes requires removal of offending DDCP Devices from the playback.

Master Control Operator Interface

A CAF DMO Master Control must present an operator interface that provides for the following basic inputs: Set Playback Speed, Set Playback 'Requested Time,' Set Playback Window, Play, Stop, Pause, Resume, and End. The Playback Requested Time is the time during the recording from which playback will begin upon a subsequent play command. There is a close, but not perfect, match between these operator commands and the transaction set that is defined in the tailoring to implement the system response to these inputs. The response of the Master Control to each user input is specified in the Tailoring Document as well. In addition, there is required status information for each joined DDCP Device to provide the operator with situational awareness for the overall system state in terms of the individual playback elements. Further, when various identified errors or other non-typical events occur, the user interface is required to provide notification to the operator. By specifying these

features, a common, or at least consistent, operating paradigm can exist across site boundaries even when the developer of the software may be different. These tailoring features are aimed at providing a level of consistency and common operating expectation among warfighters during a distributed playback.

TAILORING DDCP FOR CAF DMO

Standardization to achieve interoperability in CAF DMO has developed over the years in a manner that maintains maximum independence and autonomy for the involved contractors to develop and maintain their MTC systems. Thus, it naturally became an objective for the tailoring of DDCP to allow the MTC contractors to develop or acquire systems independently to achieve synchronized distributed playback, yet ensure that these systems would interoperate. This objective is consistent with the potential for broader adoption of CAF DMO tailored DDCP in other distributed training applications where uniform playback solutions are unlikely to be present or feasible.

As experience has amply demonstrated with DIS, even careful specification of messages structure, fields, and rules does not assure interoperation without additional efforts to limit variation in implementations that would result in incompatible software components. Therefore, to assure interoperability required some steps beyond specification of protocol and architecture to impose certain design characteristics that would provide the framework for interoperating Master Control and DDCP Device components.

Tailoring Highlights

The following list highlights the major features of the CAF DMO DDCP tailoring.

1. The pairing of records in the protocol to support command-response constructs was formalized into an explicit transaction structure with defined usage and consequences for each transaction including adherence to transaction sequencing between the Master Control and a DDCP Device.
2. DDCP message header and record field content was made specific for all DDCP messages defined for use in CAF DMO, resolving all perceived ambiguities and options in the protocol.
3. A minimal set of serious error conditions was identified and the handling of them defined.

4. Specification is provided on how to imbed all CAF DMO defined protocol messages in DIS Action Request, Action Response and Data Protocol Data Units (PDUs) to take advantage of the existing CAF DMO infrastructure for DIS message delivery.
5. A DDCP-specific “Transaction Assurance” logic is specified for assuring delivery of messages to combat loss and late delivery of messages under UDP/IP.
6. All available user control functions are defined as well as their consequences for message flow.
7. The states, relationships between states and state transitions are specified for user controls, for the Master Control program and for DDCP Device programs.
8. Details are specified for use of heartbeat and notification (no response required) messages.
9. Handling of DDCP Device Failures is specified.

Transactions in CAF DMO Tailored DDCP

The DDCP specification defines various message pairs for making requests or queries with corresponding responses. These structures are further formalized and detailed through CAF DMO tailoring to ensure that (1) any Master Control program issues entirely consistent queries/requests irrespective of its developer; (2) a Master Control program always gets responses that are timely and allow it to maintain operator awareness of DDCP Device state; (3) the request/query semantics are consistent among DDCP Devices and Master Control programs. More specifically, the CAF DMO tailoring of DDCP defines eight transactions initiated by Master Control.

The use of transactions carries the implication of sequential processing of command-response pairs between the Master Control and a given DDCP Device. The transaction names suggest their purpose: Join, Set Playback Window, Load Mission Recording, Cue, Play, Stop, Pause, and End. The transactions are formed using specific DDCP messages, and all message content is specified for each transaction’s defined purpose. Sections in the CAF DMO DDCP Tailoring Document describe usage, conditions for issuance, and expectations for receipt and response. Specific “transaction assurance” rules are defined to govern detection of lost and delayed messages and message retries. These latter provisions are required to overcome intrinsic shortcomings in UDP/IP, which is specified for DDCP network transport.

DIS Encapsulation

The idea of embedding DDCP Protocol messages in Data PDUs for transport is discussed in an Appendix to the DDCP Specification. Because the CAF DMO network (DMON) already has a fully established capability to set up and execute DIS exercises, the idea of “wrapping” DDCP in DIS was attractive as a means to simplify and limit testing for integration. CAF DMO formalization of transactions as mentioned above led naturally to adopting a slightly different approach from that suggested by the DDCP specification, which relies only on the Data PDU. In the CAF DMO tailoring, Action Request and Action Response DIS PDUs are used to carry the transaction request and reply, respectively, while Data PDUs carry messages that are simply notifications. These three PDUs are nearly identical in structure, so there is very little extra labor to use the additional PDUs, but it allows DIS level tools to differentiate easily between these important DDCP classes of messages for test, monitoring and analysis work. The use of DIS PDUs to carry DDCP messages does not reduce the need for the transaction assurance logic mentioned above, since DIS also relies on UDP for network transport.

Standardization of Errors and Error handling

It was recognized that unpredictable or inconsistent responses to error situations could be a significant problem for interoperation. Thus, the CAF DMO tailoring makes every attempt to deal with particularly problematic situations such as when no response is received, or a requested operation cannot be carried out, or a client just “disappears.” Such errors are identified and rules for responding to them are detailed.

CAF DMO O&I SAMPLE IMPLEMENTATION

To confirm the tailored protocol was implementable and effective, a sample implementation conforming to the tailored protocol was developed and demonstrated by the O&I. The implementation consists of a Master Control program and several DDCP Device programs that enable centralized, remote control over devices playing back audio, video, simulation data and other information in any combination. As described later, the F-16 Follow-on MTC system under development also integrates a CAF DMO tailored DDCP implementation.

The O&I software development was undertaken concurrent with completing the tailoring documentation. This provided a unique opportunity for synergy between the development effort and tailoring

effort. Collaboration between the development and tailoring teams assured that the implementation was thoroughly tested against up-to-date Tailoring Document requirements. Also, the final Tailoring Document benefitted from clarifications and improvements derived from development team insights and need for details not initially included.

Software Development

The primary goal of the O&I development effort was to prove the feasibility and effectiveness of the system architecture and tailoring detailed in the CAF DMO DDCP Tailoring document. To meet this goal, several software applications were developed by the O&I team. One was a Master Control Program (MCP) which could be used by a lead site to control the playback of pre-recorded data during a debrief. In addition, several playback devices were created, each integrating its own DDCP Device for communication with the MCP. These playback devices demonstrate the playback of various types of data: audio, video, and DIS simulation data.

The developed playback devices integrate commercially available components from other vendors to perform the actual output of playback data. The reasons for using other vendor components were twofold; one was to speed-up development time, but the more important reason was to demonstrate that it was possible to adapt existing playback systems to be DDCP capable. The developed audiovisual playback device is a Microsoft Windows application that utilizes an embedded Microsoft Windows Media Player to play audio and display video. The DIS playback device utilizes an external application developed by RedSim Consulting Pty Ltd. to output DIS data. Both of these devices rely on the commercial component for the heavy lifting of data output, but output is under the direct software control of the imbedded DDCP Device in response to MCP commands.

Observations

Time synchronization among devices proved to be critical, and, as the DDCP specification states, it is the key enabling feature for synchronized playback. DDCP Devices that were not time synchronized would either produce output that was not synchronous with the other playback devices or they would fail to produce any output at all. Because the CAF DMO DDCP tailoring imposes response time requirements for starting playback, a playback device whose clock was just a couple of seconds ahead of the Master's clock would be taken out of the playback by the MCP because the device would fail to send a response

message within the time required by the CAF DMO DDCP Tailoring Document. All devices involved in the recording and playback must be time synchronized to achieve completely synchronized playback.

The use of other vendor components in the playback devices helped to reduce development time and provide the necessary demonstration of the ability to integrate them, but it also exposed some challenges. The primary issue was with variability in response times from the Windows Media Player component, depending on operating system. The demo device running on Windows Vista would take up to 15 seconds to load and start playback of a video file. The same device running on Windows XP would start playback almost instantly. Illustrating the effectiveness of the DDCP synchronization mechanism, the Vista implementation detected that it was out of sync and made the necessary adjustment to get back in sync after a few seconds. This limited asynchronous playback for the viewers using Vista to only a brief period. All subsequent requests to pause and resume were instantaneous on both operating systems.

The audiovisual playback device proved to be the most valuable for verifying synchronized playback. In the laboratory, three machines were loaded with the audiovisual playback device and were placed side by side. Each of the machines had its own, locally stored copy of the same video file. The devices were commanded by the Master Control Program to begin playback of the video file. The three machines played a video clip with no noticeable variation in the audio or video. It appeared as though the devices were just video monitors displaying the same AV feed.

In a test outside the laboratory, to demonstrate that the control capability is effective over WAN connections, a DDCP Master Control Program was loaded on a machine in Orlando, Florida, and a DDCP playback device was loaded on a machine in Melbourne, Florida. The machines were on different LANs and connected through the DMON. Time synchronization amongst the machines was established using Microsoft Windows NET TIME function. The Master Control Program successfully controlled the actions of the remote playback device and synchronized the local and remote output. Another test is planned for June that will include the Orlando and Melbourne sites as well as one in Georgia.

Lessons Learned and Recommendations

The CAF DMO O&I demonstration applications have demonstrated that it is possible to facilitate distributed debriefs by enabling exercise playback using the CAF

DMO tailored DDCP. A single Master Control Program can control multiple playback devices located in remote locations. This can be achieved with only the playback control messages flowing over the WAN and keeping all playback data on each site's LAN within its own security/privacy domain.

While the need for Time Synchronization is important, expensive hardware solutions are not necessarily required. The smooth control of a debrief is possible when using Microsoft Windows based machines that have been synchronized using the built-in Windows NET TIME function. The timing values stipulated by the CAF DMO Tailoring Document can also be configured to adjust performance to actual timing capability. The user group implementing a DDCP solution conforming to the demonstrated tailoring will need to come to an agreement on the required level of synchronization; a difference of a couple of seconds may be considered insignificant in most situations. Attention is also needed to ensure that the recording devices used to capture the playback data are properly time-synchronized so that recording timestamps are consistent. The CAF DMO tailoring specifies independent synchronization to GPS for each site to avoid dependency on operational steps to ensure time-synchronization of both recording and playback.

The use of DIS to carry the DDCP protocol messages proved advantageous for use within the CAF DMO network. Since DIS is a protocol already in use, no obstacles stood in the way of the DDCP control messages getting from one point to another. Had an alternative transport been used, test, integration, and potential security issues would have prolonged the development. These possibilities for problems increase with the potential for multiple vendors to implement MCP and DDCP Devices in the future.

In order for a DDCP Device to respond to a Master Control Program within the required time, it may need to have preprocessed and/or organized the available playback data before it attempts to use it. DDCP Devices are expected to locate, load, and start playback very quickly (sub-second), though there are provisions to tolerate a slow device. Users tend to expect playback will be similar to their home DVR experience. In order to provide the greatest level of convenience, the recording process should have recorded data available and ready for immediate playback by organizing, indexing, and storing it in an optimal fashion for playback as it is received.

Architectural Option Implementation

The demonstrated O&I DDCP Devices provide an example of directly integrating a DDCP interface with a playback capability in a single application, reflecting the option illustrated in Site 3 of Figure 1. Sometimes this approach may not be possible or will involve complexity resulting from specifics of the existing playback system implementation. To potentially reduce this risk and simplify the integration of existing playback systems for CAF DMO, the experience gained in the just-described implementation effort was leveraged to develop a solution representing the architectural option illustrated in Figure 1, Site 1.

This implementation encapsulates the entire MCP-to-DDCP Device interaction in a Generic Media Control Application (GMCA) intended to be used in a DDCP Device implementation as a "front end" to provide all direct interactions with the MCP. The GMCA presents a software level interface (using XML RPC in this case) to a playback system specific software element that needs to know nothing about DDCP. The approach is illustrated in Figure 2.

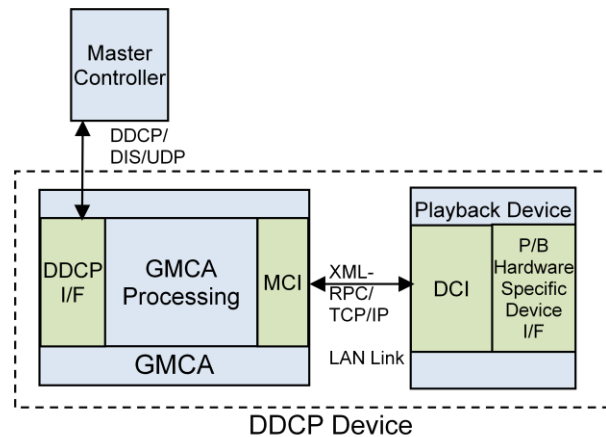

Figure 2. GMCA based DDCP Device Architecture

Its advantage is that it allows a single MCP developer (in this case the O&I) to provide playback system integrators with a defined software level representation (shown in Figure 2 as Master Control Interface (MCI) to Device Control Interface (DCI)) of the DDCP control interface rather than a protocol specification document, as a tool for integration.

By using this strategy, the potential for differing interpretations of the CAF DMO Tailored DDCP Document to result in incompatible design choices is further reduced. The GMCA approach is probably a good one for adapting multiple playback devices to a single Master Control on a one-off basis. It is not so good for adapting a single device (as a commercial BDB vendor might want to do) for use with multiple

Master Controls programs. Nevertheless, while the DDCP remains an “emerging” standard, this approach may be useful for leveraging the control messaging standard while speeding and reducing implementation costs for a given application domain such as CAF DMO. The GMCA has been used to successfully re-implement some of the O&I DDCP Device demonstration programs.

BOEING DESIGN EFFORT BASED ON CAF DMO TAILORED DDCP

The F-16 Mission Training Center (MTC) debrief system shown in Figure 3 was developed from 2009 through 2010. This system incorporates the CAF DMO tailored DDCP specification among many other features to benefit the warfighter. By incorporating the CAF DMO tailored DDCP specification, a synchronized debrief can be achieved between multiple F-16 training centers, and even multiple CAF DMO training centers that support DDCP, without the need to retransmit recorded data over the WAN.

The F-16 Follow-on MTC debrief system supports seating for up to 8 observers, an instructor, and a technical operator. There are six large 46” LCD displays for viewing the scenario playback. Data recorded for playback include DIS network data for situational awareness, cockpit display video, and cockpit switch repeaters. A video teleconferencing system provides communication with remote participants. A technical operator has a computer station for controlling the data playback and displays. A digital whiteboard allows annotations to be created and shared with the local and distributed participants.



Figure 3. F-16 Follow-on Debrief System

A key environment requirement for ensuring that DDCP can maintain tight synchronization is to use a reliable source of time synchronization like GPS.

Thus, the system incorporates use of a GPS receiver to keep a Network Time Protocol (NTP) server synchronized with global time as required by the CAF DMO tailored DDCP. Use of a reliable and highly accurate NTP implementation is critical to maintain synchronization accuracy within 30ms Synchronization (Pitz, Armstrong, 2007).

Some lessons were learned from implementing the CAF DMO tailored DDCP specification during the development of the F-16 MTC Follow-on debrief system. The use of DIS PDUs to transport DDCP messages on the WAN described earlier is not specified in a way that maintains a sufficiently distinct boundary between DDCP and DIS to implement DDCP as a purely “stacked” network protocol layer on top of DIS. Consequently, this causes a challenge in understanding the rules and processing of both protocols. For instance, the request ID field of an Action Request/Response DIS PDU is required to represent the contained DDCP transaction message type. Though there is arguable value in allowing such cross-over, it may be beneficial as CAF DMO or SISO standardization goes forward to consider eliminating it as a requirement. It may be possible to allow, but not require, DDCP-related information in the DIS wrapper for implementations that wish to take advantage of the resulting visibility at the DIS level of what DDCP content the DIS packets are carrying.

Heartbeats, a familiar DIS concept, are used in the CAF DMO tailored DDCP by both DDCP Device programs and the Master Control programs to maintain mutual awareness of their continued presence and health. Currently, heartbeat messages use the same packet format as both state change request and synchronization messages. This overloading of the message type makes processing heartbeats complicated and might be another candidate for consideration for future changes to the standard. Separation of these functions into distinct message types in the underlying DDCP specification may simplify implementation.

Finally, implementing selection of playback session data as specified in the CAF DMO tailoring presented a challenge for the F-16 MTC Follow-on system. Under the tailoring, when initiating a distributed debrief session, a master device will attach remote debrief clients to the session. The master then specifies a playback time window for the session and announces that to all attached clients. Based on this time window, the clients identify matching playback data sets back to the master. The master is then responsible for selecting which data set each connected client should play based on user inputs and identify it for the client upon issuing a playback start request. Once playback is running,

clients must locally manage any interruptions in their data and specifics of local data organization invisible to the master. This approach proved problematic for the F-16 MTC Follow-On implementation, because the information made available to the master was not sufficient for it to base its decision on. The F-16 MTC Follow-On debrief solution worked around this issue by allowing clients to autonomously select the session to load when joining a debrief session. However, in order to comply with CAF DMO tailored DDCP, the client will pretend to honor the master playback time window and load mission requests, but will always use the locally selected session for playback. Future standardization efforts should consider support of alternate or additional scenario playback selection methods for CAF DMO, which could leverage autonomous behavior of remote sites.

Challenges such as those just described were not unexpected considering this early-stage application of DDCP as an emerging standard. They also have not diminished the value added to the F-16 MTC Follow-On debrief system through integration of the CAF DMO tailored DDCP specification. Indeed, this debrief system is certainly a more capable and complete solution as a result of implementing the distributed synchronized playback in this way. With this system and CAF DMO tailored DDCP compliant systems to follow, the capability to conduct synchronized debrief is greatly increased with enormous benefit to the warfighter.

WHAT THE FUTURE HOLDS

DDCP as an Open Standard

As a result of the work in developing DDCP, encountering recurring program requirements, and an observation of customer dissatisfaction with fielded debrief solutions, a collaboration of industry members started the Simulation Interoperability Standards Organization (SISO) DDCP Study Group in 2007. The aim of this study group was to investigate the need for a distributed debrief standard. The DDCP specification was offered as an open standard through the study group. In addition, DDCP was presented to the CAF DMO Standards Development Working Group (SDWG) as a possible standard for that community, where it has been tailored for use as reported in this paper. The rationale for opening the DDCP specification to these communities was to jump-start the standardization process. The process of standardization can be lengthy and laborious, and having an existing specification can accelerate and simplify the process.

The SISO study group held four meetings at Simulation Interoperability Workshop (SIW) conferences and wrote a final report. The final report concluded that enough industry interest exists to create a SISO Product Development Group (PDG) for establishing an interoperable distributed debrief standard. The vision for this standard is to enable a broad range of debrief solutions to implement basic distributed debrief synchronization, while eliminating common technical limitations. Ideally, the standard would also identify a framework of enhanced capabilities that solution providers could implement for increased benefit.

Towards this further goal, the DDCP Study Group released a survey in 2008 requesting interest in the areas of

Time synchronization - maintaining all participants on a coordinated timeline

View synchronization – includes bookmarking, transfer of replay control, tactical annotation, and others.

Tactical annotation - the presentation of planning and intelligence data concerning the battlefield situational awareness and battle plans as an overlay within the main display of a viewer

Bookmarking - the marking of specific contexts and events during a training exercise

Transfer of replay control – passing of a single point of control from site to site or person to person

Other than time synchronization, these capabilities go well beyond the capability initially offered by the existing DDCP specification. They arise for consideration and take on varying importance depending on the community concerned. For example, the CAF DMO community has explicitly chosen to live without any of these capabilities other than time synchronization in order to accelerate the timeline to having basic playback capability. Of the remaining ones, CAF DMO is most interested in bookmarking, which is common in existing systems. Bookmarking and transfer of playback control have the closest relation to the current DDCP protocol and support could probably be added without undo difficulty.

The final SISO DDCP Study Group report was accepted at the Spring 2010 Simulation Interoperability Workshop. The report concluded that there is indeed adequate need for a distributed debrief standard. However, the start of a Product Development Group should be delayed until more industry participation can be obtained.

Initial discussion in the study group about the nature of a distributed debrief standard lead to the concept of a distributed debrief object model as the possible product. An object model approach would lend itself to adaptation to multiple implementations such as DIS, HLA, or even TENA. Furthermore, bridging these disparate implementations becomes a straightforward exercise as conformance to the object model ensures compatibility. Finally, variations or enhancements to the current protocol have also been discussed, such as reformulation of the message structure as XML and support for other transport mechanisms such as TCP or, at a higher level, HTTP or Extensible Messaging and Presence Protocol (XMPP).

Implementation and Deployment of CAF DMO Synchronized Distributed Playback

At this writing, CAF DMO is working cost issues associated with implementing DDCP based solutions for its many systems and expanding site count. The potential value of distributed playback is not in question, but the re-tooling of diverse debrief applications already in use combined with meeting existing shortfalls in local recording and playback capabilities presents a sizeable economic and engineering challenge. As progress towards resolving these matters continues, further demonstrations of the already developed software in ever more realistic contexts are planned (risk reduction), and strategies for controlling cost and timelines to make the capability widely available within CAF DMO are being explored.

The goal remains a basic playback capability to begin with, deferring enhancements to the future. In this way, experience with a successful initial capability can point the way to upgrades having the greatest cost benefit.

SUMMARY AND CONCLUSIONS

This paper has described CAF DMO's pursuit of synchronized distributed playback of independently recorded exercise data as part of its overall debrief capability and the steps undertaken to date to achieve that objective. The steps reported include requirements assessment, market survey of available playback options, the adoption of the synchronization approach using the DDCP emerging standard, and an overview of the tailoring and implementation to date of the CAF DMO tailored DDCP. The conclusion is that the DDCP provides a solid foundation for required CAF DMO functionality. Tailoring of the use of DDCP has focused on meeting expectations for predictable responsiveness to operator inputs and assurance that implementations by different vendors can reasonably be expected to interoperate. Implementations of the tailored DDCP have been successfully demonstrated to offer the many benefits of synchronized distributed playback as an alternative to approaches like redistribution of playback data and adoptions of common systems. CAF DMO, through its Standards Development Working Group, is continuing efforts to cost effectively bring implementation to its systems.

REFERENCES

- CAF DMO DDCP Tailoring Document, Version 1.0 (2010). CAF DMO Standards Development Working Group.
- DDCP Study Group Final Report (2010). Simulation Interoperability Standards Organization.
- Pitz, R.; Armstrong, C. (2007). Advanced Distributed Debrief for Joint and Coalition Training. Proceedings of 2007 Interservice/Industry Training, Simulation, and Education Conference.
- Travers, V.; Ferguson, W.; Langevin, T. (2006). A Federating Protocol for Distributed After Action Review. Proceedings of 2006 Interservice/Industry Training, Simulation, and Education Conference.
- Jinkerson, J.; Lane, L.; Merket, D. (2009). Proceedings of the 2009 Spring Simulation Interoperability Workshop.